

SHELTER

ASSEMBLY MANUAL

Model-6012030DR-M

W18.3 x L36.6 x H9.15m

With 3.05m arch distance

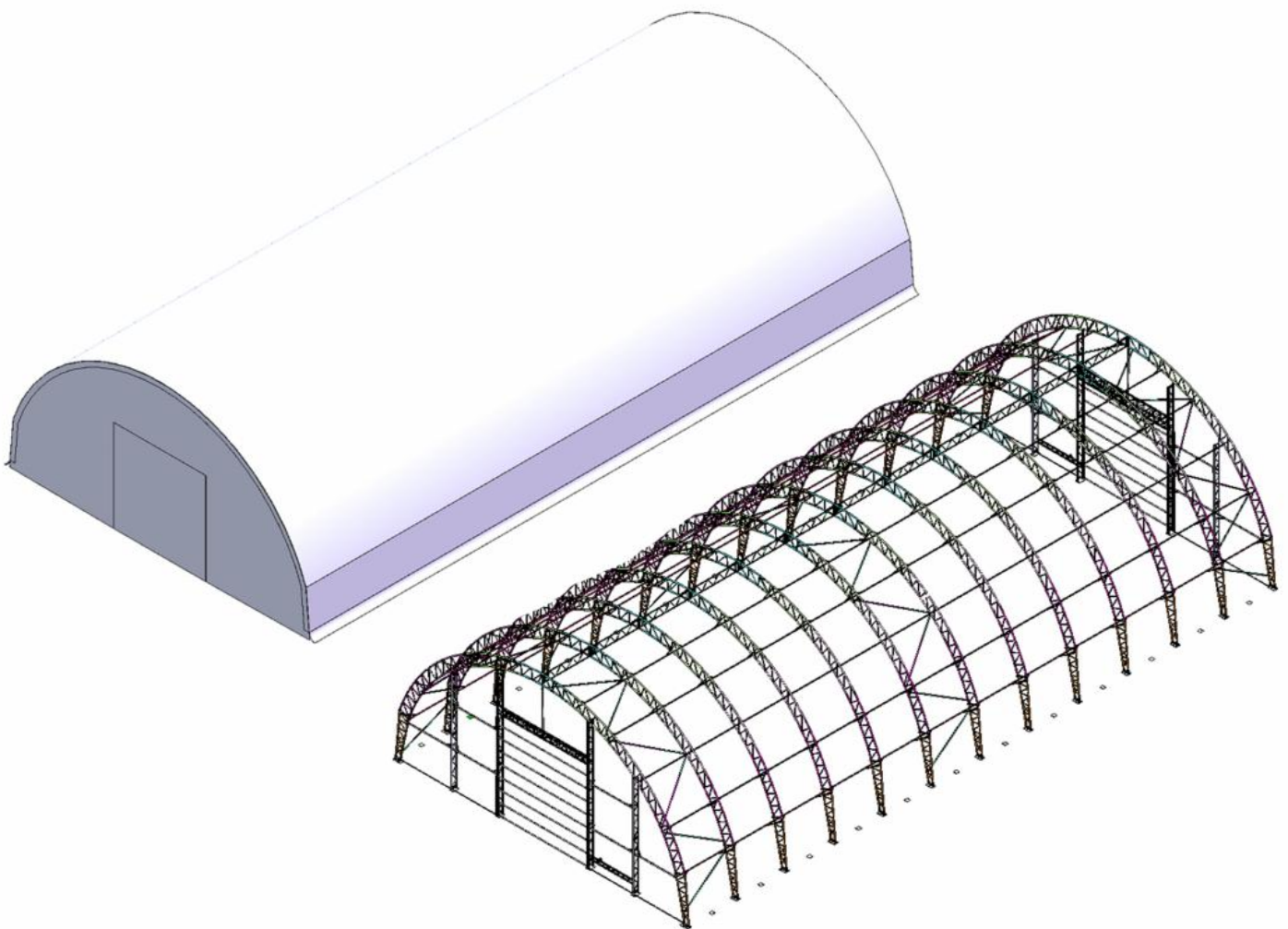

SPECIFICATION

Width: 18.3m Length: 36.6m Height: 9.15m

Door dimension: W5.49m x H5.6m

IMPORTANT-----READ MANUAL FIRST

Improper site preparation, Assembly and Maintenance may invalidate warranty and cause unnecessary and costly mistake. If you have any questions contact your local dealer.

For User Friendly assembly we have identified each individual component with the part code as indicated in the parts list. Please refer to the part code numbers and drawing to ensure problem free assembly.





It's necessary to tighten the roof fabric enough to avoid "hammocks" on the roof and also re-tighten once or twice again after a few months of use. This is important when assembly in cold weather (autumn and winter) because the fabric is stiff then and when we got the sun and warm weather afterwards it will make the fabric "slack" again and need to be re-tighten before next winter.





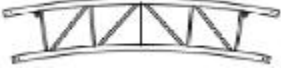
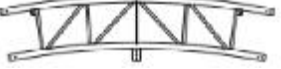
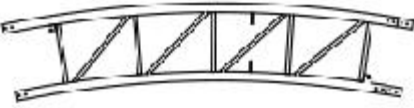



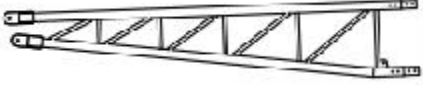

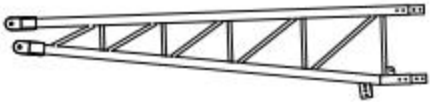

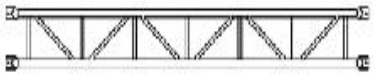
It's the owners responsibility to take of snow immediately if not slide off by itself.









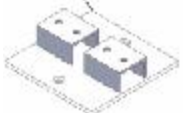

READ ALL INSTRUCTIONS BEFORE ASSEMBLY



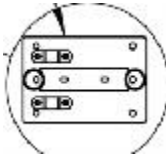
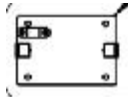
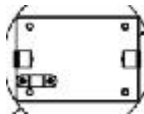



1. Keep work area clean. Cluttered areas invite injuries. Do not set up near snow drifts, in slippery places, in high winds, or wet location.
2. Keep children away. All children should be kept away from the work area.
3. Don't over reach. Keep proper footing and balance at all times.
4. Do not assemble in under the influence of alcohol or drugs. Read warning labels on prescriptions to determine if your judgment or reflexes are impaired while taking drugs. If there is any doubt, do not assemble.
5. Be aware of possible windy conditions; fasten the bases in concrete if these conditions are likely to occur. Remove the cover during hurricane.
6. Be careful with power and heat sources. Do not keep heat sources near the tarpaulin. Do not expose to open flame.
7. Be aware of personal safety during assembly and use. Be careful not to pinch fingers with clips and tubes when assembling: when using makes sure there is adequate ventilation for exhaust and other dangerous fumes.



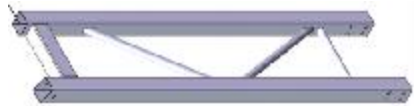







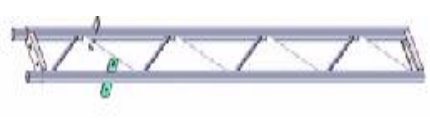

PART LIST





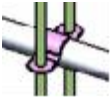





Part Code	Description		Qty
1	Top roof tube		11
1A	Top roof tube in the front and back door		2
2	Roof upper curving tube		22
2A	Roof upper curving tube in the front and back door		4
3	Roof middle curving tube		22
3A	Roof middle curving tube in the front and back door		4
4	Side lower curving tube		26
5	Lower curving tube		22













5A	Lower curving tube in front and back door		4
6	Supporting Tube between the arch		78
7	Double Trussed Purlin		12
8	Purlin		120
9	Diagonal Support Tube For purlin		240
10	Diagonal Support Tube		24
11A	Diagonal Support Female Tube		12
11B	Diagonal Support Male Tube		12
12	Clips $\phi 48$		242
13	Clips $\phi 60$		94
15A	Tension Tube For Roof Cover		24
15B	Shoulder Tension Tube For Roof Cover		2
16	60 Clamping Piece		320
17	PVC Protective Cover		78
18A	Drawing die belt and die tube base		12

18B	Drawing die belt base		12
L1	Left Corner Base Plate		2
R1	Right Corner Base Plate		2
LR2	Middle Base Plate		22
LR3	Base plate for front and back panel		4
L2	Left Base plate for mechanical door		2
R2	Right Base plate for mechanical door		2
20A	Lower door track for mechanical door at left		2
20B	Lower door track for mechanical door at right		2
21A	Middle door track for mechanical door at left		2
21B	Middle door track for mechanical door at right		2
22A	Upper door track for mechanical door at left		2

22B	Upper door track for mechanical door at right		2
23A	U-shaped plate for door jamb - outer sleeve		16
23B	U-shaped plate for door jamb - inner sleeve		16
24	Mechanical Door Side - Latching Bar		4
25A	Door beam on mechanical door at left		2
25B	Door beam on mechanical door at right		2
26	Vertical support tube for mechanical door beam		2
27A	Door Dropping Tube-Female Tube		16
27B	Door Dropping Tube-Male Tube		16
28	Mechanical wheel square tube		2
29	Double-wheel - mechanical wheel wire rope		2

30	Lower standing leg on both doors at left		2
31	Lower standing leg on both doors at right		2
32A	Upper standing leg on both doors at left		2
32B	Upper standing leg on both doors at right		2
33A	Mechanical door - $\phi 60$ - Horizontal tube		8
33B	Mechanical door - $\phi 60$ - Side horizontal tube		4
34	Horizontal pipe diagonal support pipe		20
35A	Tensioning tube for front and back door		4
35B	Tensioning tube for the side of front and back door		4
36	$\text{\O}38$ Protection - Half Arc		8
37	Stake peg M12		16
38	Stake peg M16		188
39	$\phi 32$ PVC Tube		88
40	Roof Cover		1
41	Front panel with mechanical door		2
U8L	Weighted ratchet left		34

U8R	Weighted ratchet right		34
U1	Rope		1
42	Tarpaulin partition panel		26
U2	Small ratchet with band		660
U10	Wide tension band		42
S21	hexagon bolt 16*50mm		84
S27	plain washer M16		168
S33	flange nut M16		84
S12	Carriage bolt 8*80mm		680
S29	flange nut M8		680
S18	hexagon bolt 10*30mm		640

S15	hexagon bolt 10*90mm		146
S16	hexagon bolt 10*60mm		10
S30	flange nut M10		796
S17	hexagon bolt 10*50mm		370
S25	plain washer M10		740
S35	hexagon nut M10		370
S19	hexagon bolt M12*40		300
S26	plain washer M12		600
S31	flange nut M12		300
U17	round plug $\phi 60$		4
U15	round plug $\phi 38$		16
U12	Slack ball		4

EQUIPMENT AND TOOLS FOR INSTALLATION

1. Measuring Tape
2. String for alignment
3. Stake
4. Ladder or Scissors Lift
5. Sledge Hammer
6. Drill
7. Wrench
8. Knife

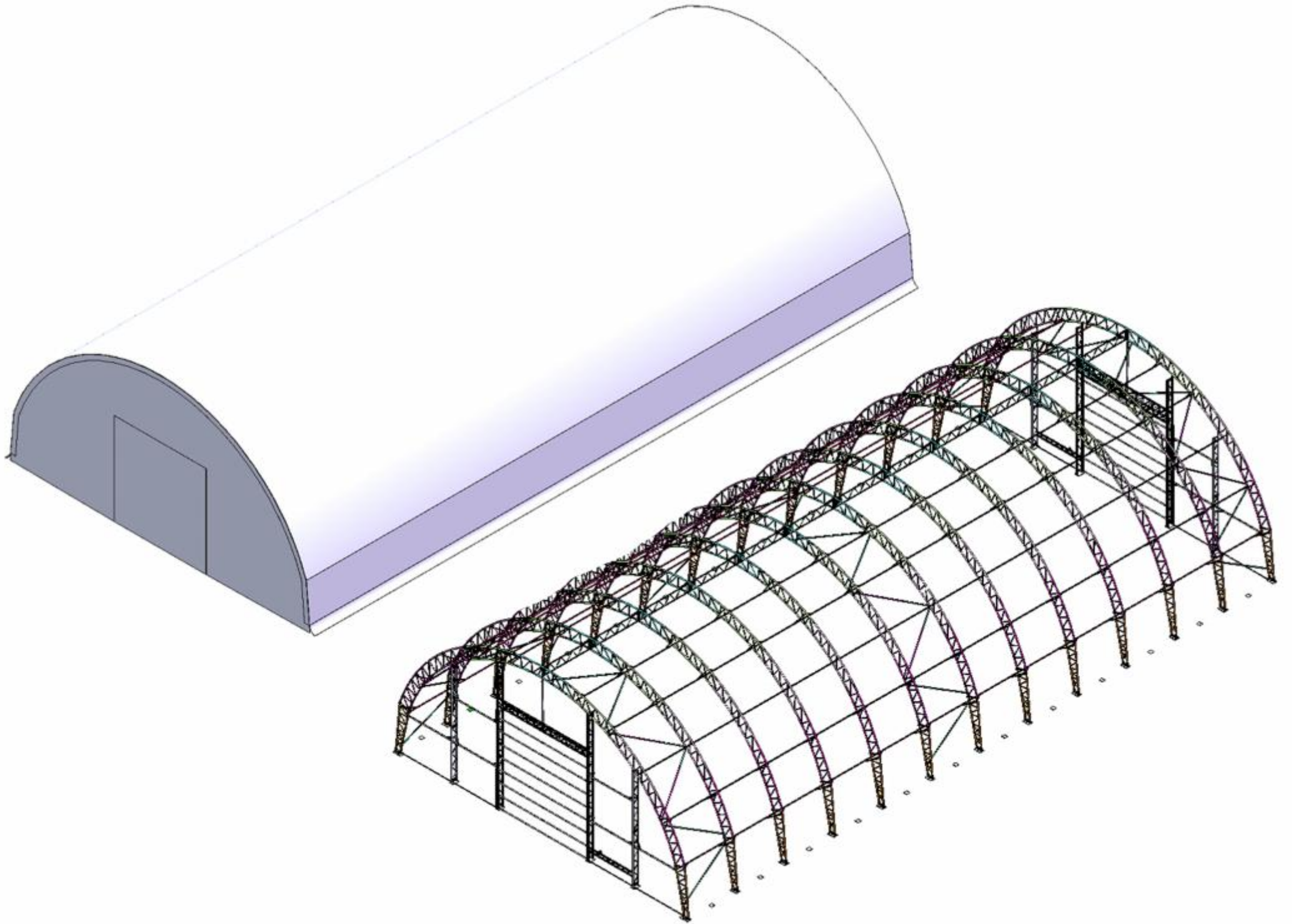



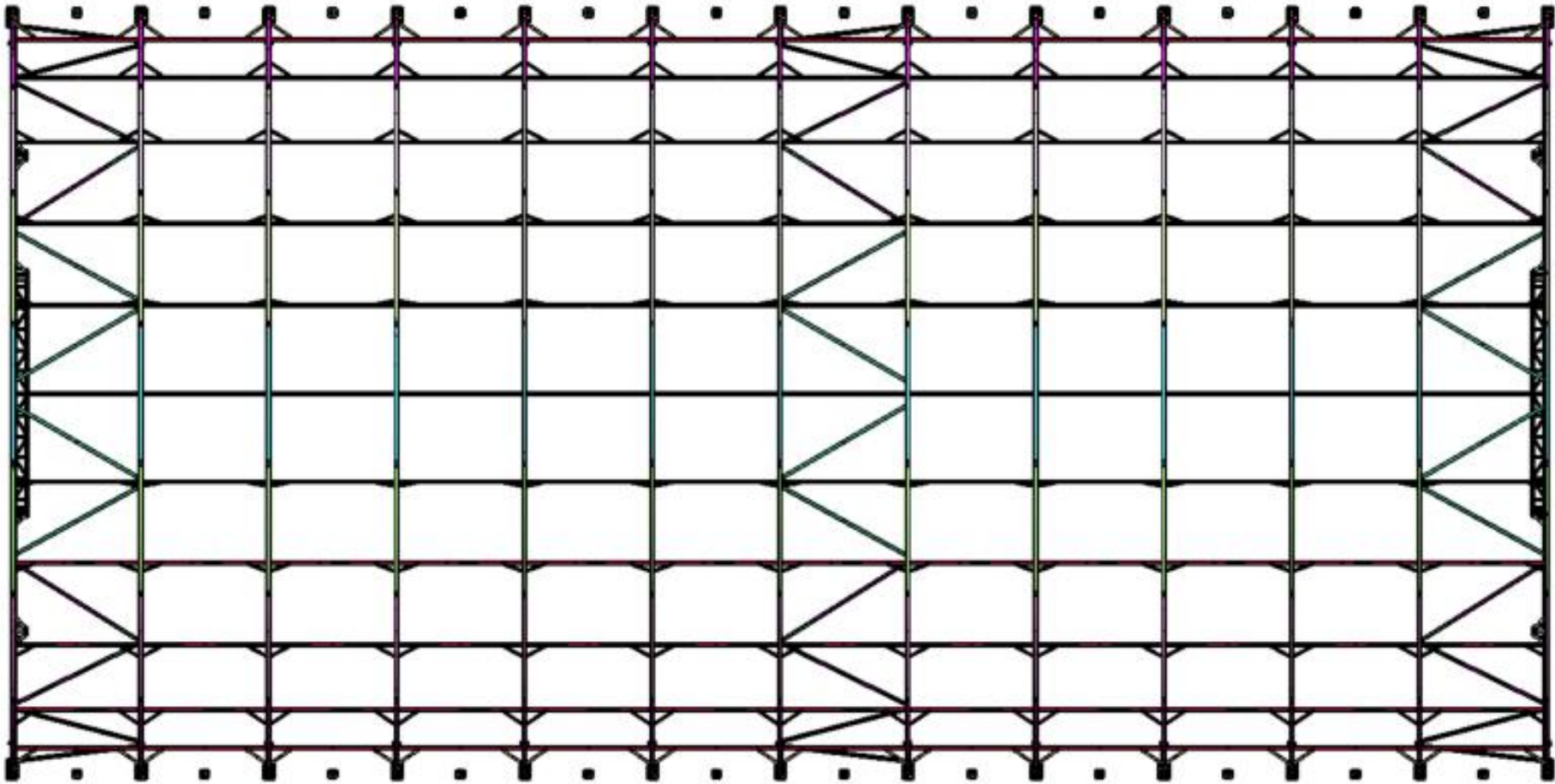

Frame

Foundation placement

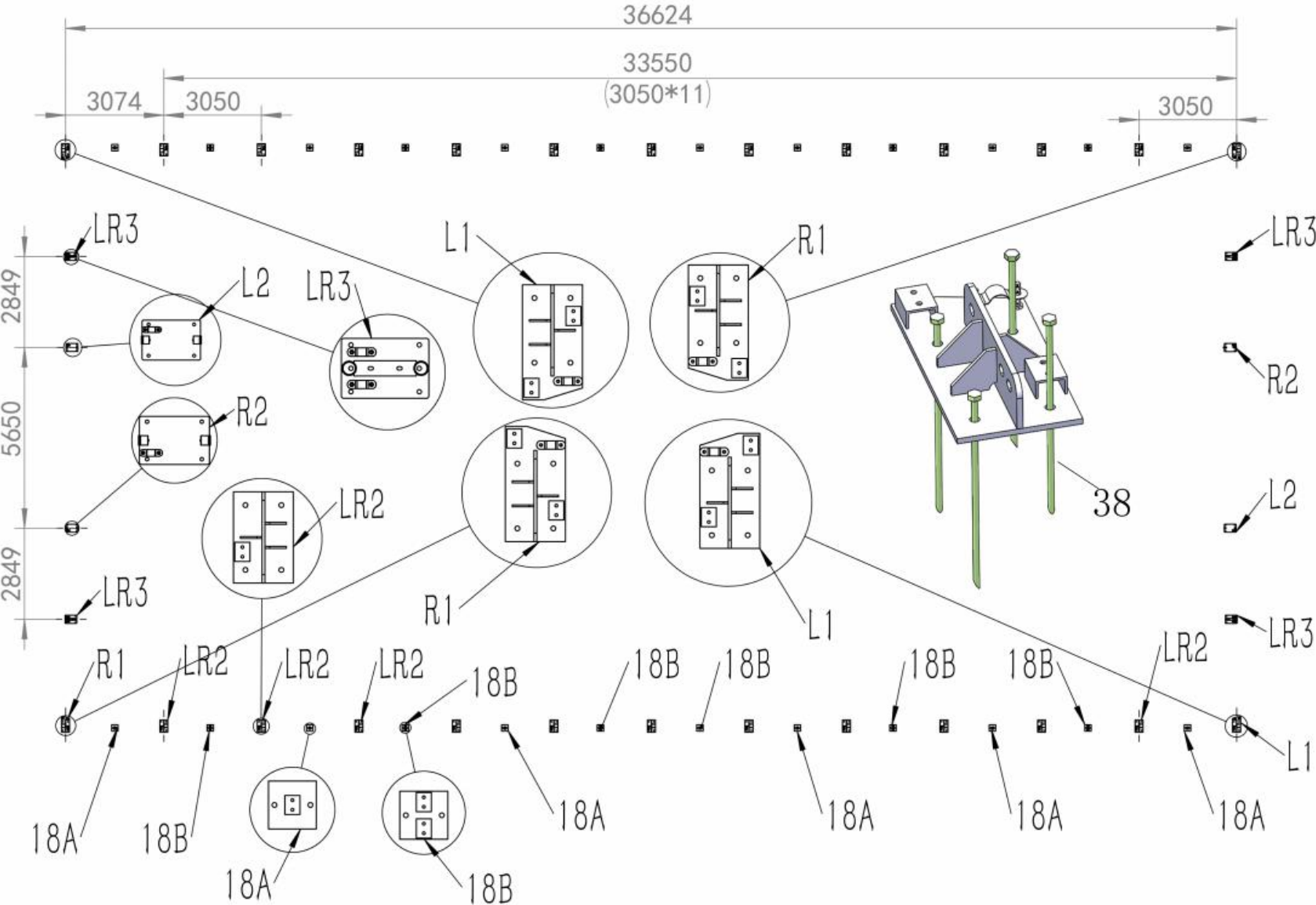

Figure 1

1. The measurement is from center to center of tubes on the base plates. Referring to the above diagram and confirm the place of base plates. There are there holes on the plates for stake pegs.
2. Please refer to the diagram (Figure 1) to place the base plates.
3. As Figure 1 shows each Base plate is equipped with 4 pieces of Stake pegs.(No.38) or Expand screw
4. Mark the stake peg hold through the base plate by using the stake peg. Move the base plates away and the mark determines where the stake peg will be.

Note: The stake peg apply for normal conditions, not suitable to the rock ground,frozen soil and concrete ground.

The Expand screw apply for hard surface of the ground, customer may choose Stake peg or Expand screw according to your need.

A—FRAME INSTALLATION

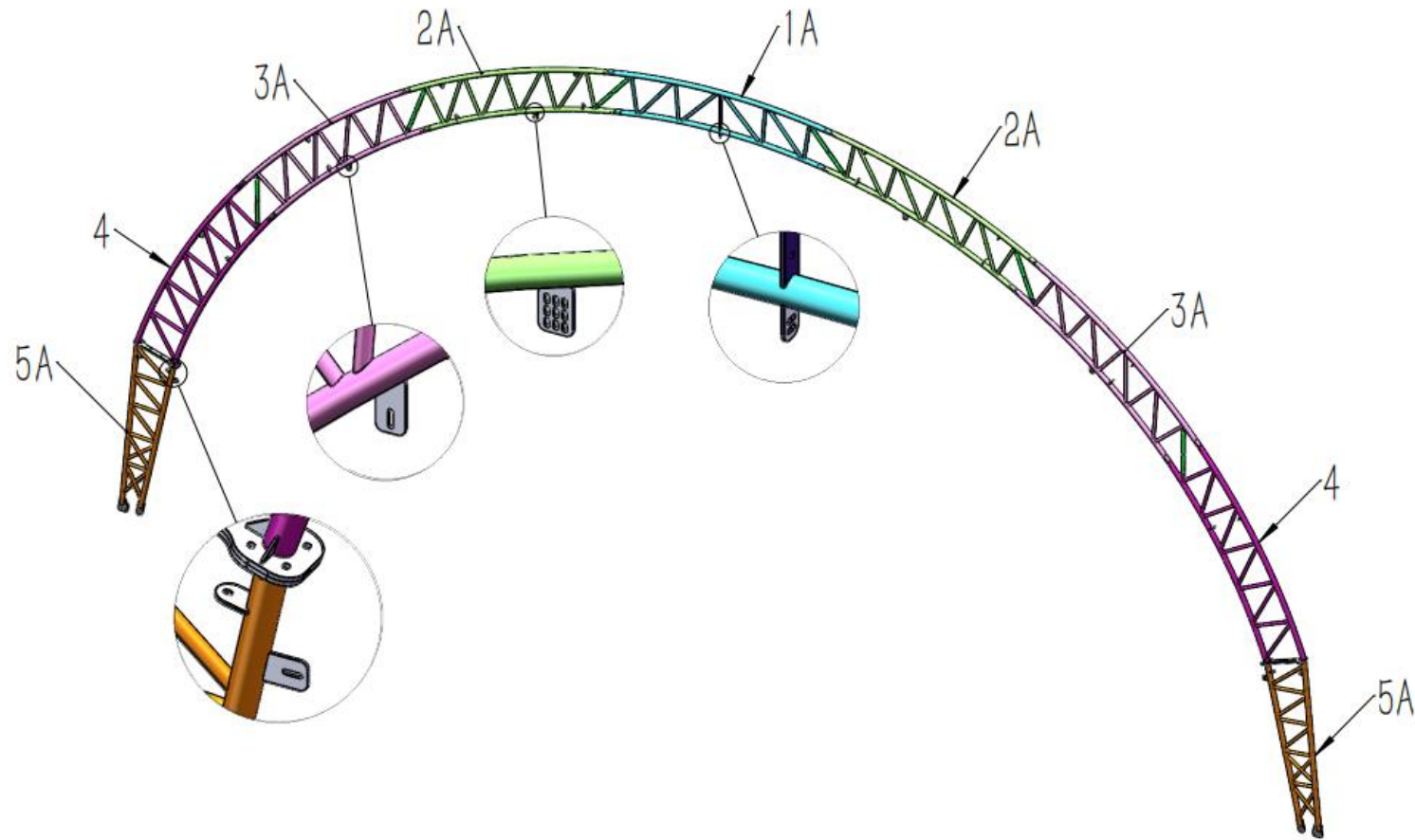

Figure 2

1. As Figure 2 shown to find one Top roof tube in the front and back door (No.1A), two Roof upper curving tube in the front and back door(No. 2A), two Roof middle curving tube in the front and back door (No. 3A) ,two Side lower curving tube(4) , two Lower curving tube in front and back door (5A)and assemble the first group and final group of arch with Supporting Tube between the arch (No.6). **DO NOT install the screw on the top of the truss where the fabric will rest.**

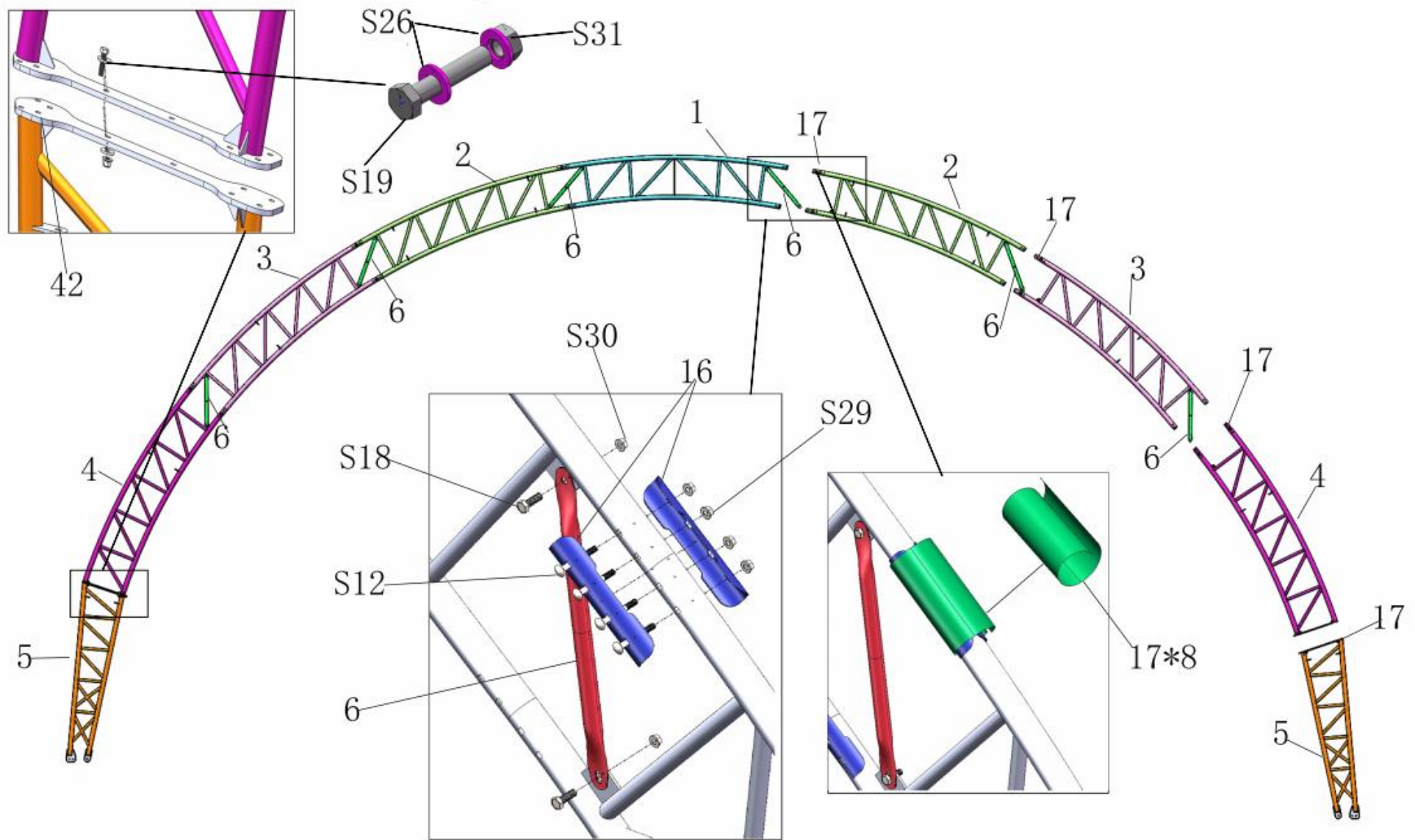

Figure 3

2. As Figure 3 shown to find one Top roof tube (No.1), two Roof upper curving tube (No. 2), two Roof middle curving tube at shoulder (No. 3) ,two

Side lower curving tube (No. 4), and assemble every group arch with Supporting Tube between the arch (No.6). Use S18 and S30 to fix part 6 between each group of arch. Side lower curving tube(No.4) and Lower curving tube(No.5) are connected with No.42. **DO NOT install the screw on the top of the truss where the fabric will rest.**

Note: Top Roof tube, Roof curving tube, Roof middle curving tube, Side lower curving tube and Lower curving tube (No.1A,2A,3A,4A&5A) which are welded with steel plates for front and back doors are different from the middle arch.(Figure 2)

3. As figure 3 shown, use the Supporting Tube between the arch(No.6) to connect the Top roof tube (No.1) with hexagon bolt 10*30mm (No. S18). Then put the PVC protective cover on the outer of connection of the arch to protect the roof cover from scratched by the outer joint. Assemble the rest of the other group double truss arch like this.

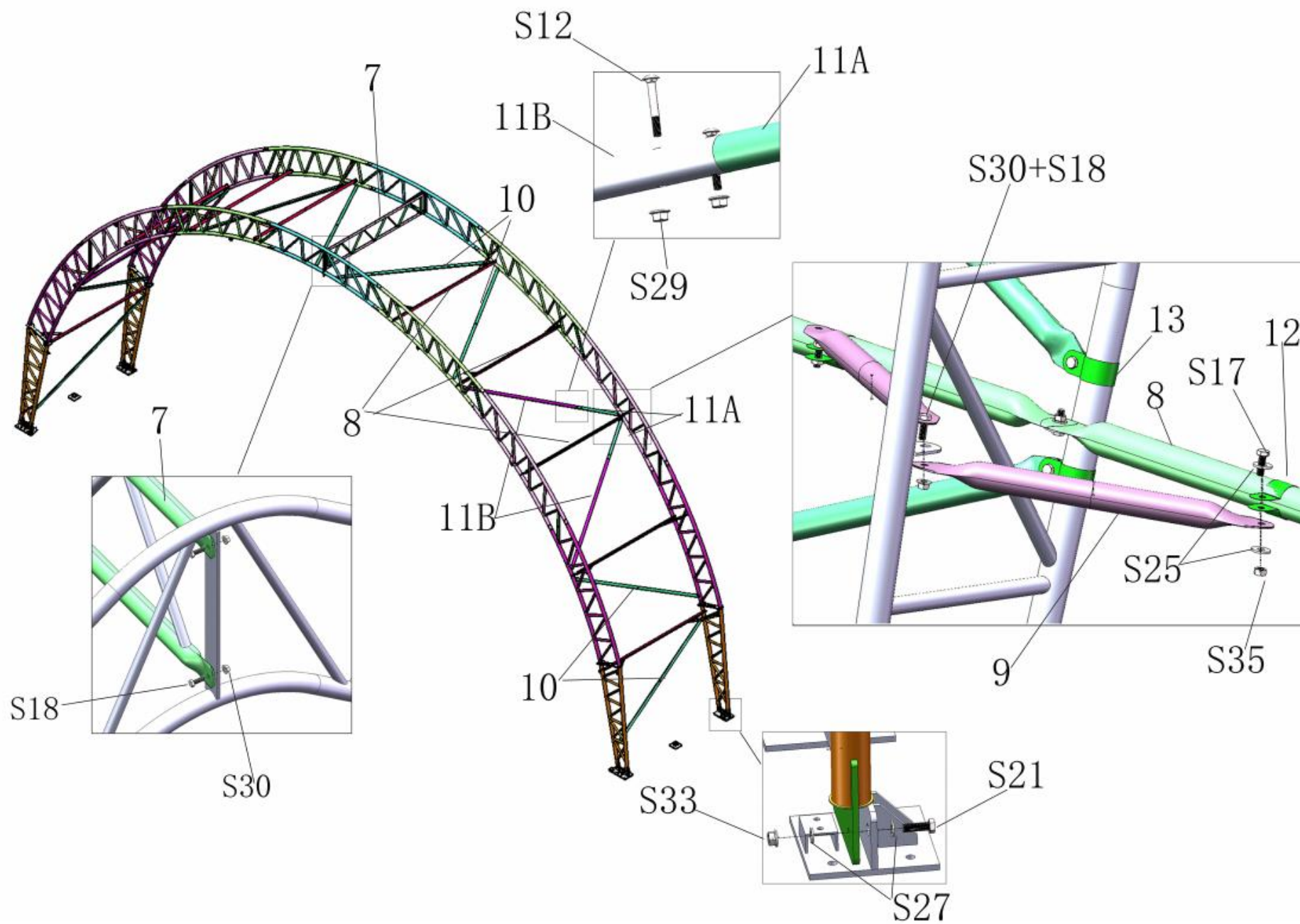

Figure 4

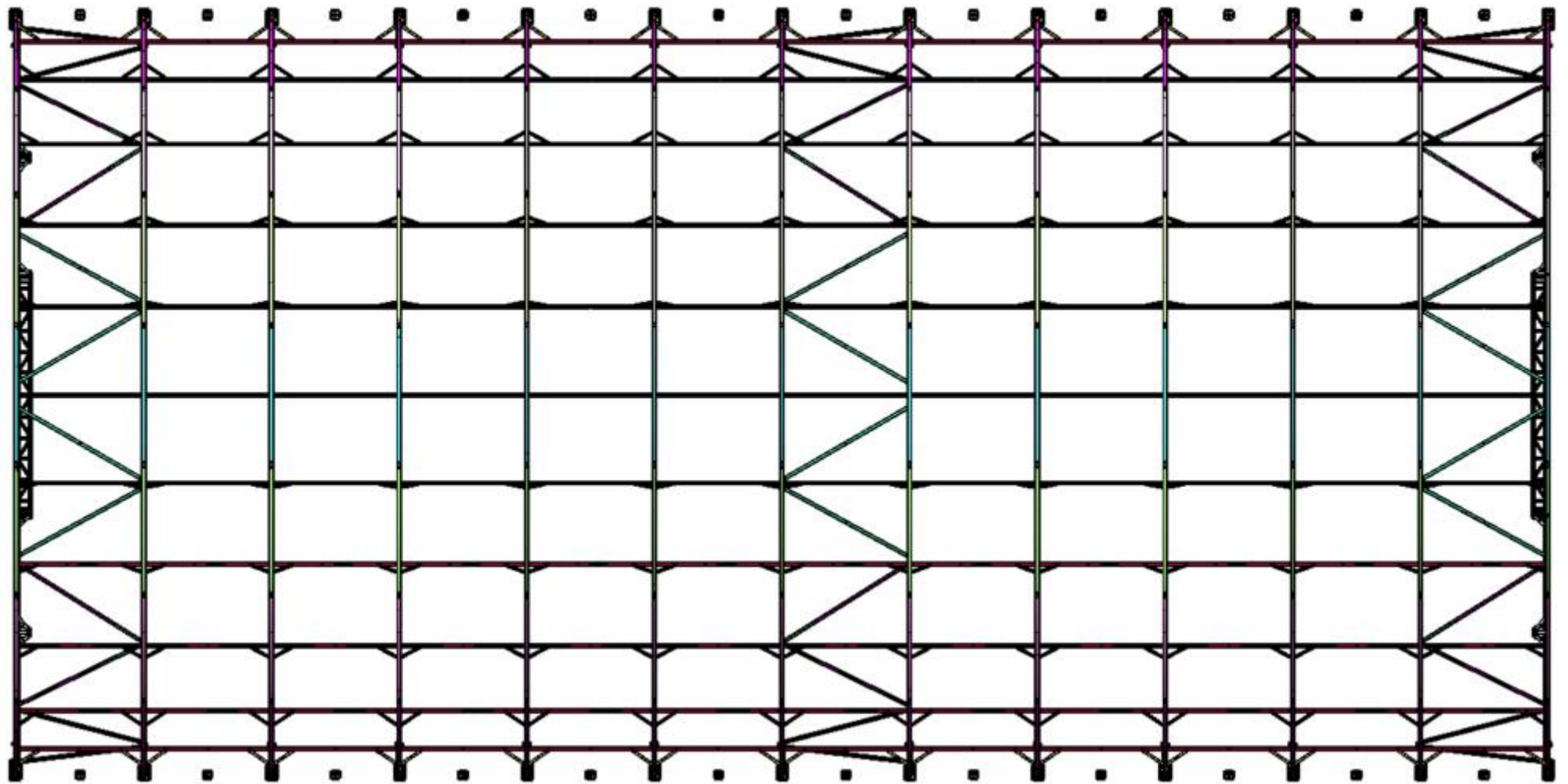

Figure 5

4. Above Figure 4 shown when finish installing all the arches into the base plates, use Double Trussed Purlins (No.7) to connect them by Screw M10x30 (No.S18) . Then use Purlins(No.8) to connect the arches by Screw M10X50 (No.17). In this turn, fix all other purlins. Finished stretch frame as below(Figure 5)
5. As figure 4 shown to find Diagonal Support Female Tube(No.11A) and Diagonal Support Male Tube(No.11B) and assemble every group support tube with hexagon flange nut M8(No.S29) and hexagon bolt M12*40(No.S19). Then connect the diagonal support tube (No. 9) to arch by using clip(No.12).

Note: Before install the arch,please install the clip first.

Before install the Diagonal Support Tube For purlin,please install the clip first.

B-DOOR INSTALLATION

B1 Door frame installation

1. Find the relative components and assemble the front and back door accordingly(Figure 6,7,8)

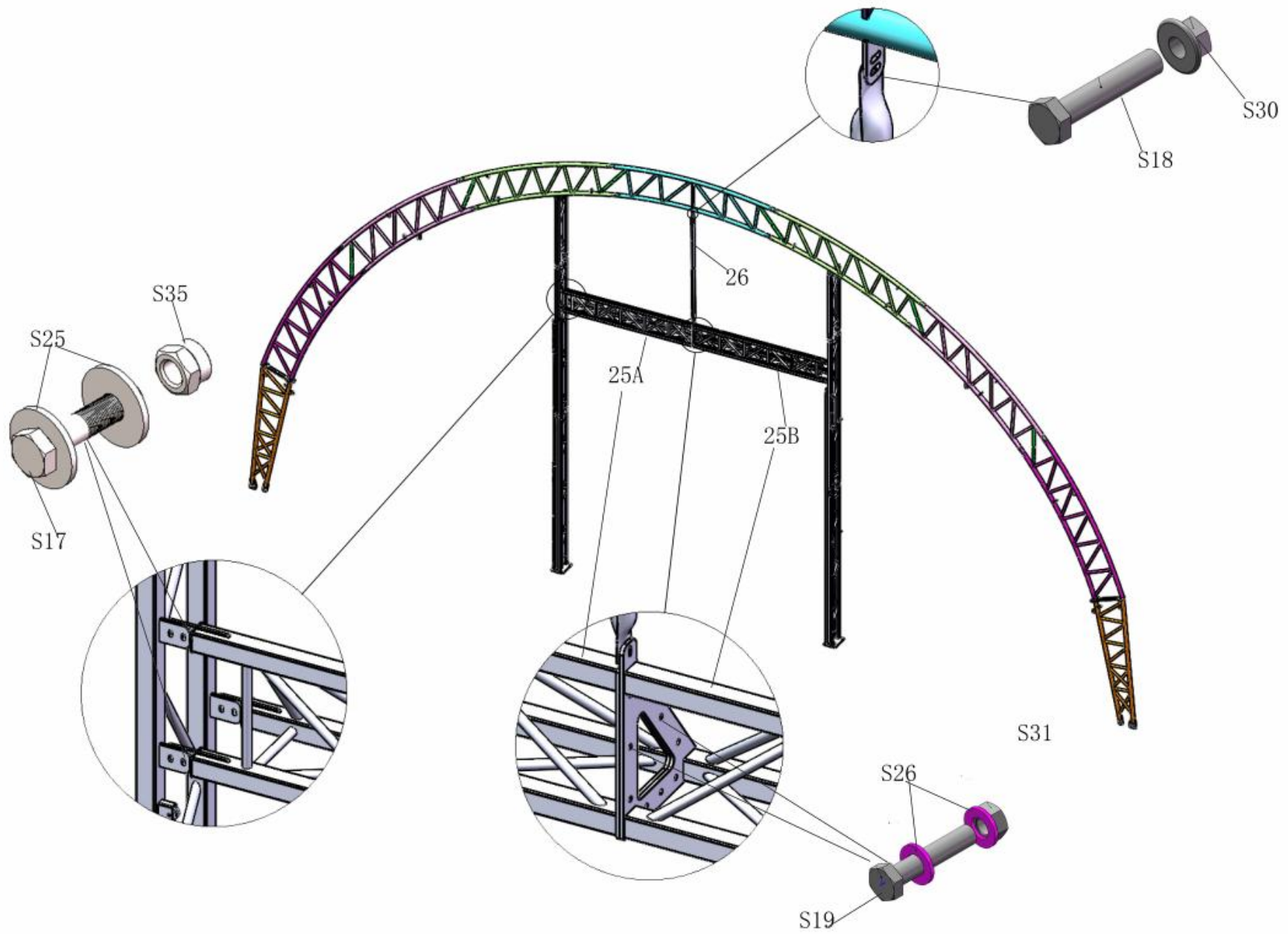

Figure 7

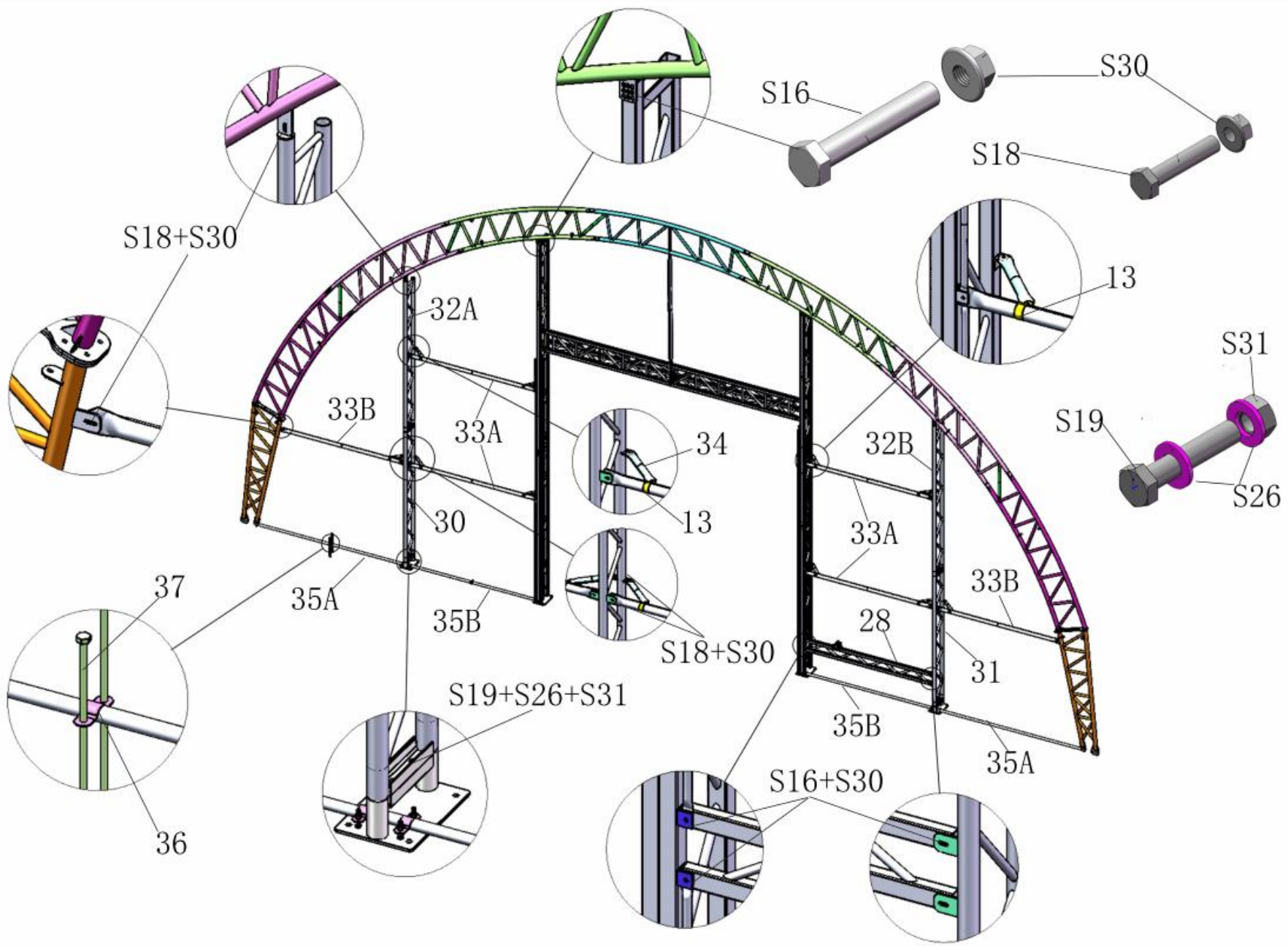

Figure 8

2. Fix Vertical support tube for mechanical door beam(No.26) on Top roof tube in the front and back door (No.1A) and install the Door beam on mechanical door at left (No.25A) and connect the Door beam on mechanical door at right (No.25B) by No.S19 as figure 7 shows.

B2 Front and back cover installation

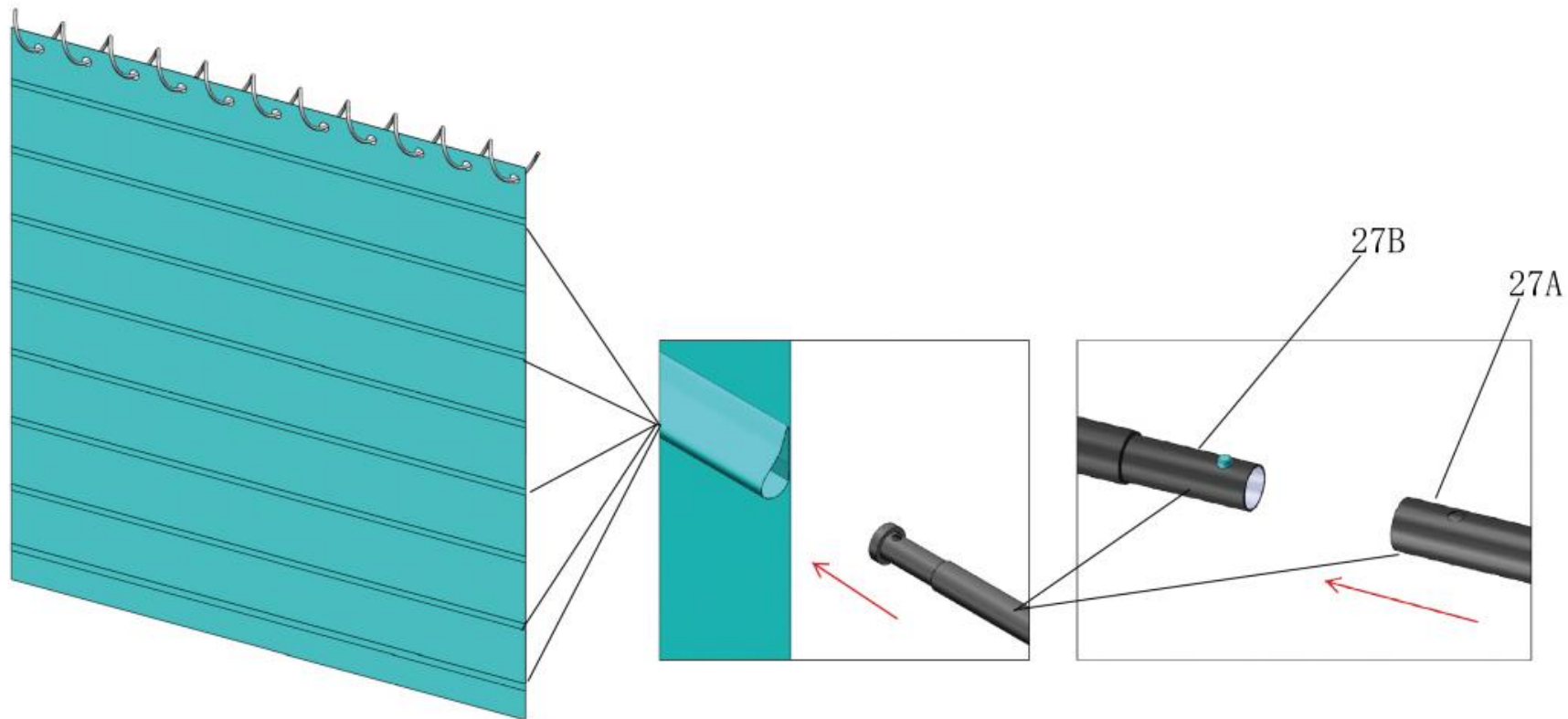

Figure 9

1. Insert the Door Dropping Tube (No.27A&27B) into the bottom of Front and Back door cover.Thread the Steel Wire (No.29) into each group of Door Dropping Tube(part No. 27A&27B), then install one front and back door cover on the door frame and knit this cover to the tubes. Finally tie the Steel Wire for Door onto the Mechanical wheel (part No.29).

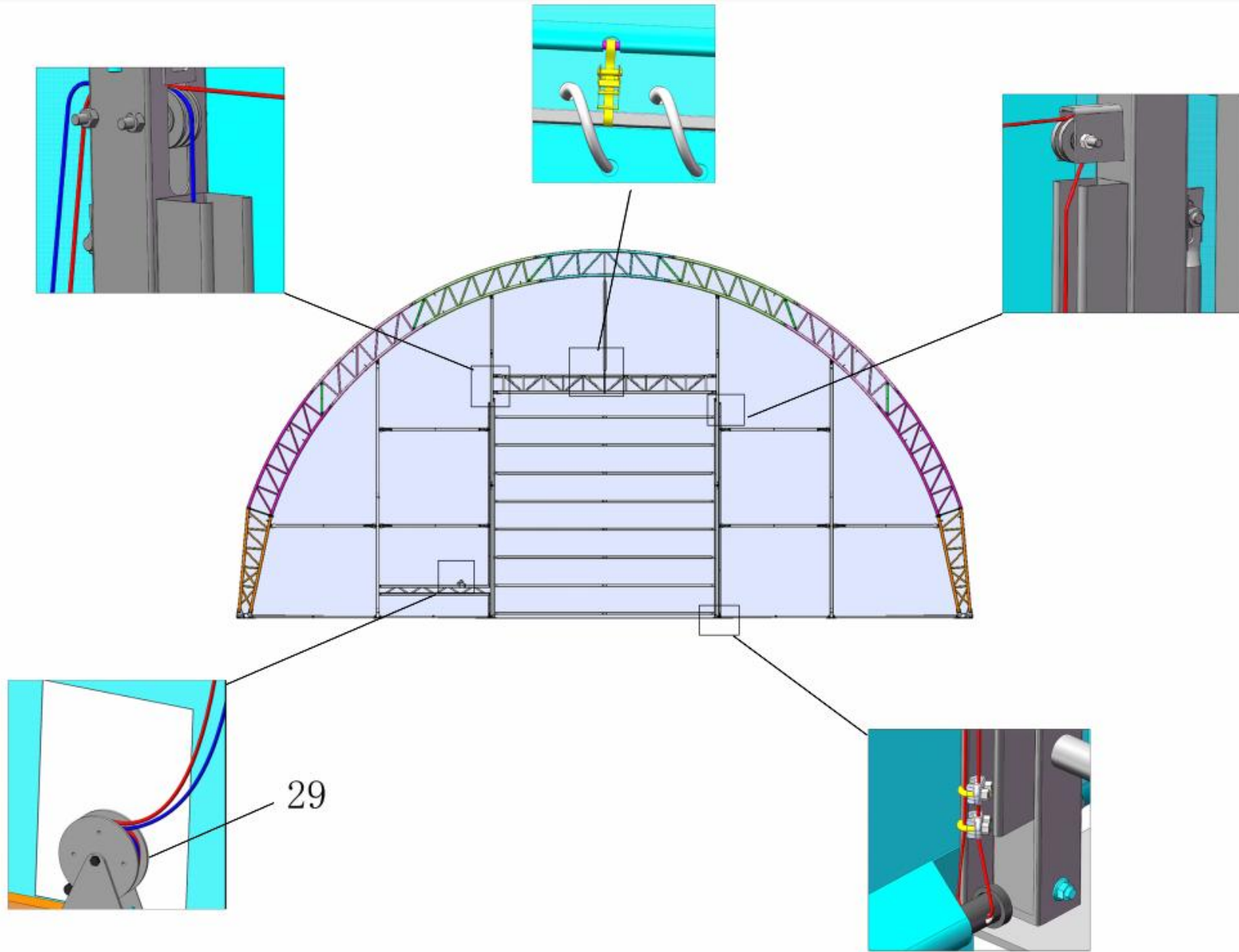

Figure 10

2. Use small ratchet (No. U2) on Front and Back cover to tensioning tubes evenly. The end covers are tied to the frame (Roof, Middle & Lower Bent Tube) by ratchet. They are also been secured to the end frame (door tube and side rail) by Knitting Rope.

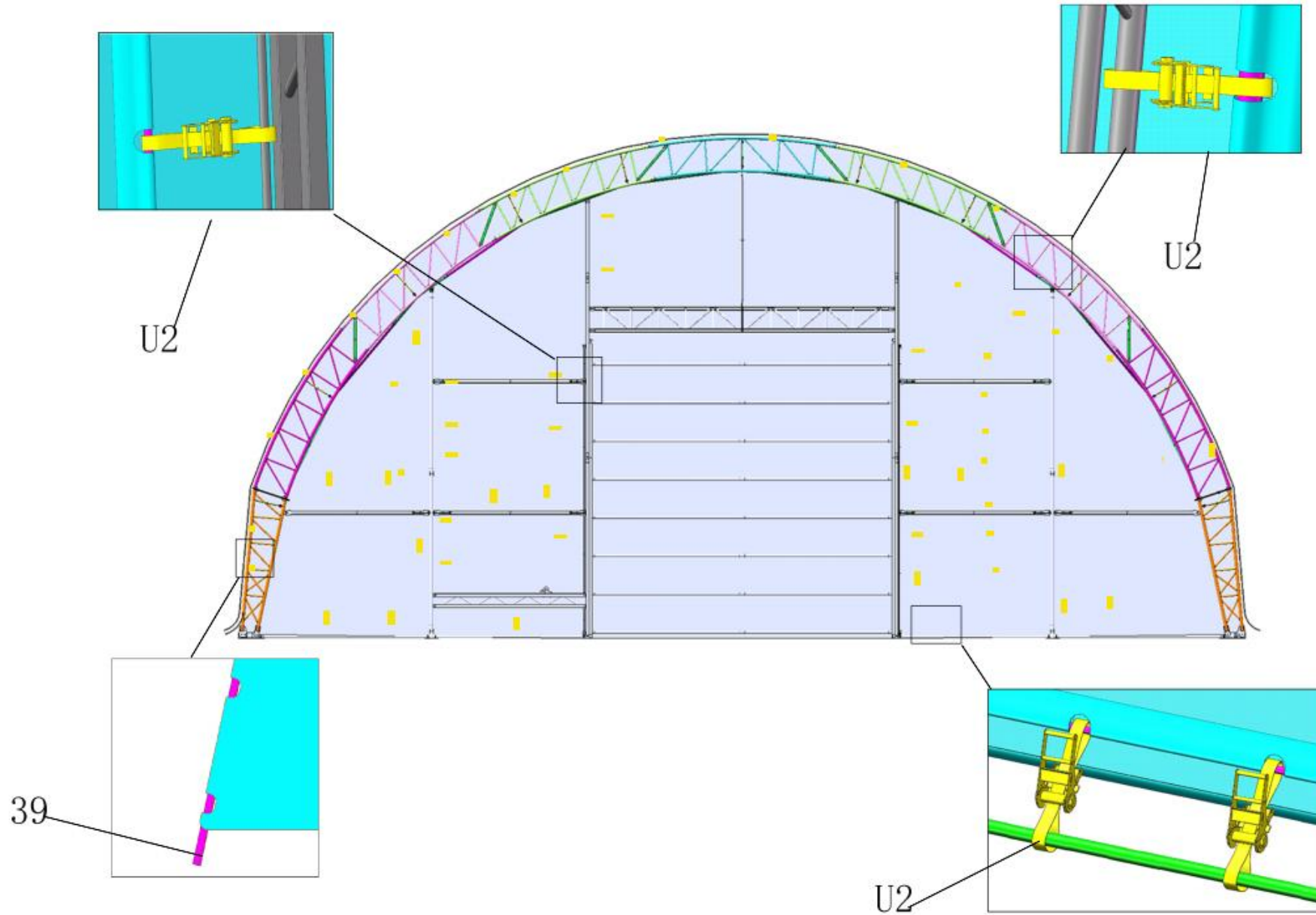

Figure 11

3. Make the cover well tidy the Back Cover and Front Cover. Fasten the band inside the end of the roof cover, make the cover well fold to the frame and tie the end of the band to the Clips on Base Plates at four corners.

4. When you close the door, we can use the Lock steel wire for door (No.29) and Lock steel wire for the wrench handle to fix. (Figure 11)

C-ROOF COVER INSTALLATION

NOTE: DO NOT install the cover onto the frame of your building in high wind conditions. A slight breeze is the most advantageous for cover installation. To take advantage of the breeze, pull the cover up over the arches with the breeze blowing in the cover like a sail filled with air

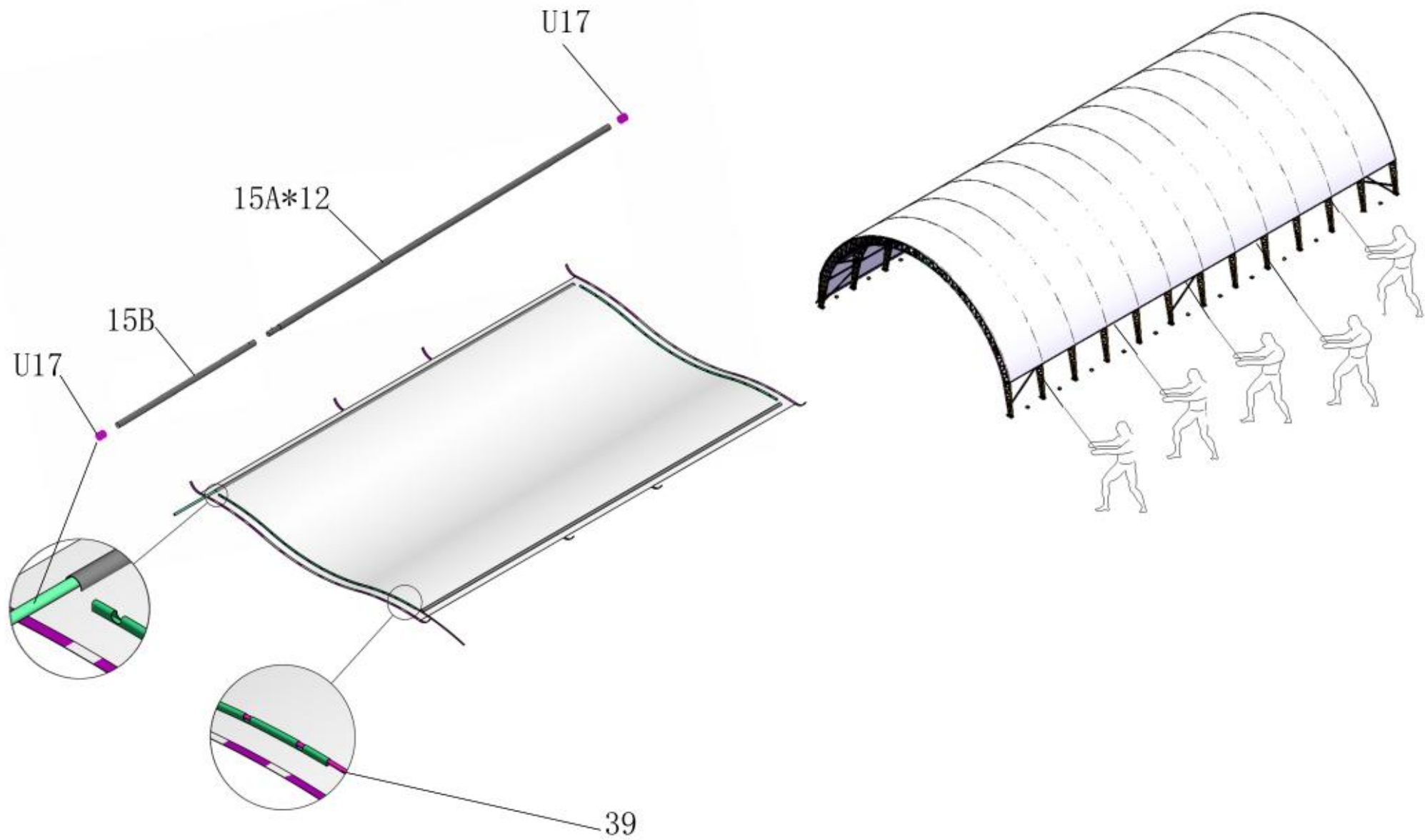

Figure 12

1. Put tubes 15A&15B into the cover and also put the plastic plugs(No.U17) onto the tubes. Throw the ropes over the frame and use the 15A&15 tubes in every pockets to fix the rope. Insert the ϕ 32 PVC tube(No.39) into the pocket of the front and back door. Then you drag the roof including all tubes 15A&15B on another side over the frame

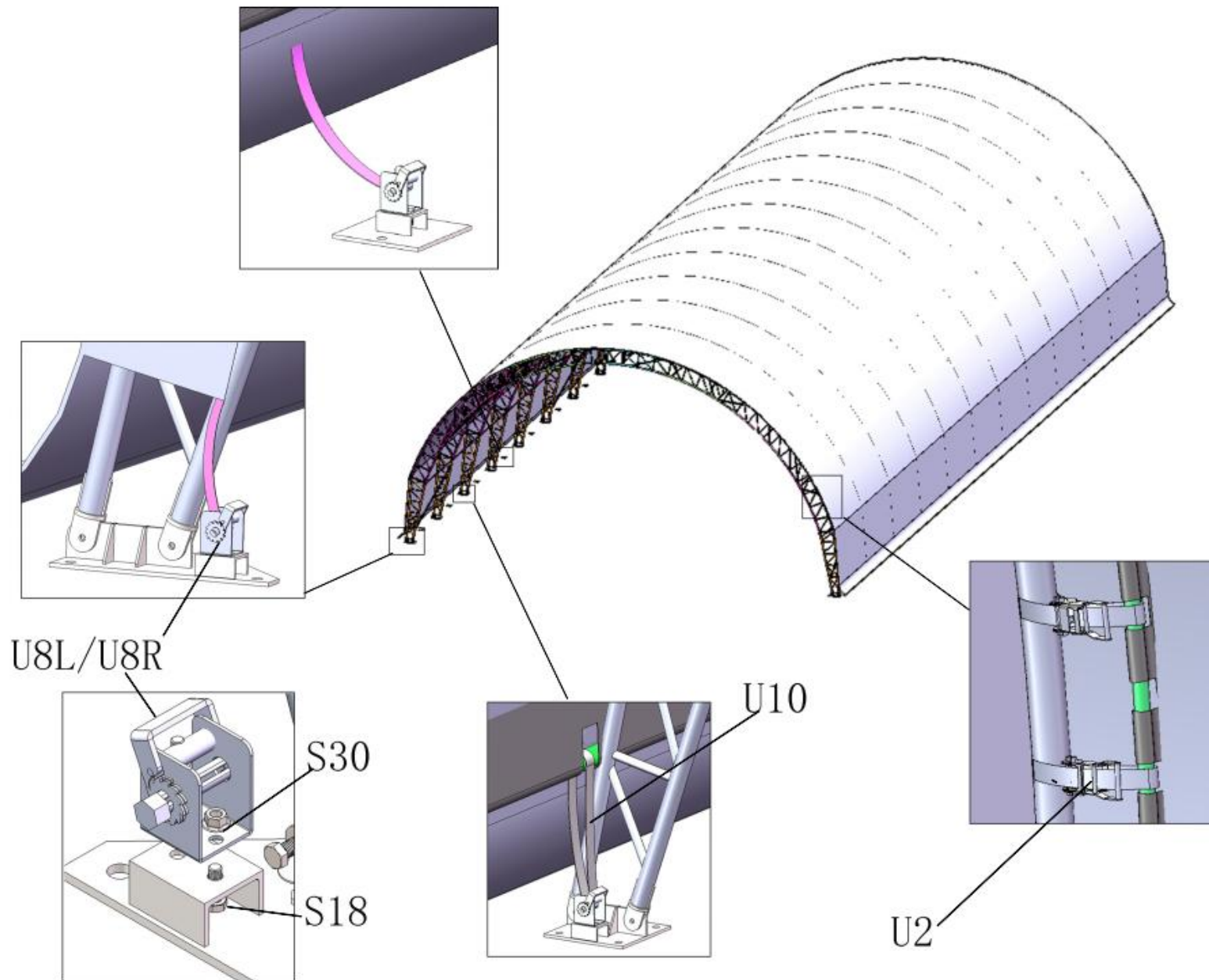

Figure 13

2. Pull the roof cover over the frame **EVENLY, CAREFULLY AND SLOWLY**. Insert the tension tubes for roof cover (No.40) and PVC tube (No. 39)

into the two edges of roof cover pipe pockets and cut pockets respond to each inner base plate. Loosely secure the wide tension band (No.U10) in the ratchet (No.U8L/U8R)DO NOT TIGHTEN. Adjust the cover so that it is square and evenly centered on the frame.

NOW THE INSTALLATION IS FINISHED, PLEASE ASJUST THE BASE PLATES VERY MONTH.

Notice: 1. The calculation of wind load is based on the height of the highest point of the shelter not exceeding 10m.

2. All calculations of the load bearing capacity is based on the reasonable tensioning of the roof cover and the smoothness of the roof cover.